

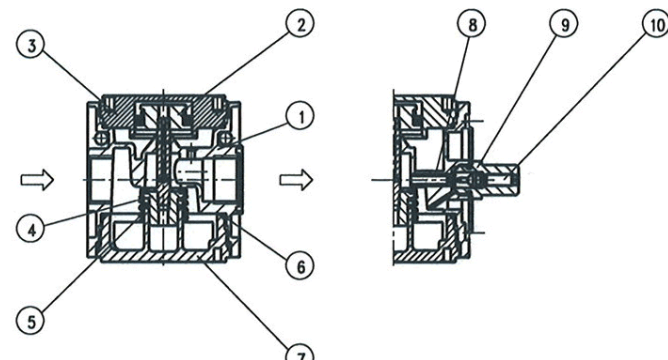



item	type	A 11 F		
port size		G 1/4		
description		seat valve, manipulation by secondary pressure		
mounting		arbitrary		
supply pressure		Pe max. 16 bar, Pe min. 2 bar		
aperture pressure		50% Pe (only for closed systems)		
media and ambient temperature		max. 60 °C (other temperature ranges available upon request)		
nominal discharge		Qn 1000 l/min (Pe = 6 bar, delta P = 1 bar)		
fixing		bracket or through 2 holes in the body		
weight		0,326 kg		





replacement parts  (repair kit: ESA-A.11)

no	description	material	order-no.
1	body	Zinc - Z 410	---
2	plunger	NBR - Al	
3	bonnet	Al	---
4	valve cone	NBR - brass	
5	spring	S.11-4 stainless steel	5.4011.04.500
6	O-Ring 30 x 2	NBR	
7	bonnet	POM	---
8	blast pipe	brass	---
9	stem guide	NBR - brass	---
10	regulating spindle	NBR - brass	---

application information

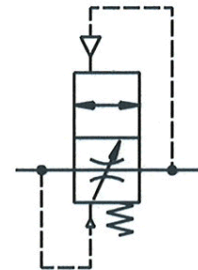
- easy block assembly for components to be connected in series
- interlocking of several individual devices requires coupling kit(s) KP 11
- interlocking of several individual devices with narrow distributor Z 11 requires coupling kit(s) KP 11 Z
- by turning the regulating spindle the duration of filling ist adjustable



series 1

ordering information

A	11	F
type <input style="width: 80%;" type="text"/>	<input style="width: 80%;" type="text"/>	<input style="width: 80%;" type="text"/>
1 port size <input style="width: 80%;" type="text"/>	<input style="width: 80%;" type="text"/>	2 option <input style="width: 80%;" type="text"/>

ordering example: A 11 F

1	port size	
	11	G 1/4
2	options	

dimensions (mm)

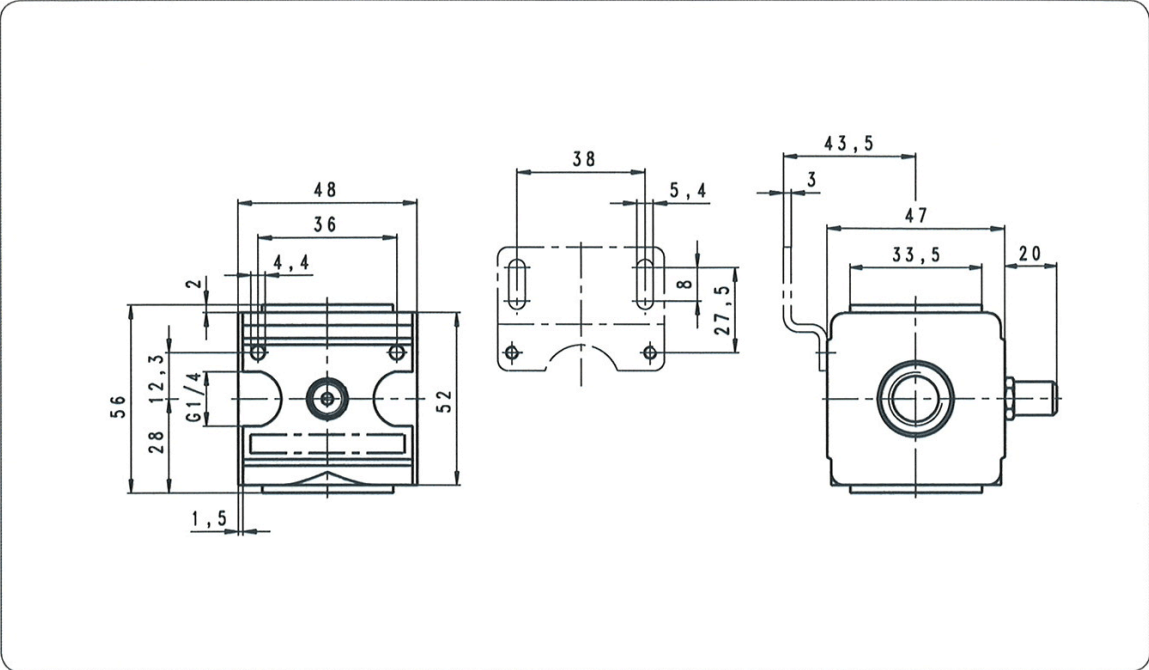

charging characteristics

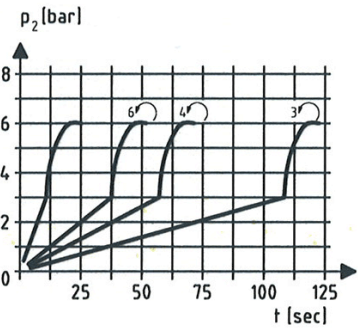

Reference volume $V = 10$ l
 Duration of filling adjustable

various application

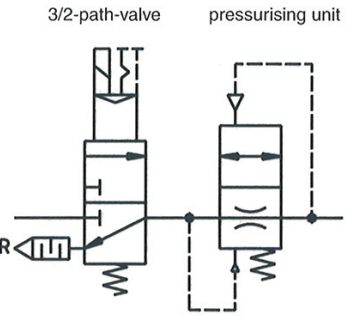

Aeration of the mechanism over throttle setting of the pressurising unit.
 When $P_2 \geq 50\%$ P1 opens full profile.
 Pressure release at R

accessories

mounting bracket

type: ZW 11

Four empty rectangular boxes are provided for listing other accessories.